



Standard Test Method for Determining Strength of Gap-Filling Adhesive Bonds in Shear by Compression Loading¹

This standard is issued under the fixed designation D 3931; the number immediately following the designation indicates the year of original adoption or, in the case of revision, the year of last revision. A number in parentheses indicates the year of last reapproval. A superscript epsilon (ε) indicates an editorial change since the last revision or reapproval.

1. Scope

1.1 This test method covers the determination of comparative shear properties of gap-filling adhesives in wood-to-wood joints at specified thicknesses of bondline in the dry condition, when tested on standard specimens under specified conditions of preparation, conditioning, and loading in compression. This test method is intended as an evaluation of gap-filling adhesives such as those used to bond plywood to lumber, lumber to lumber, and other similar materials in building constructions.

1.2 This test method also may be used to determine shear properties of gap-filling adhesives in species of wood and in thicknesses of bondline other than those specified for the comparative tests of shear properties within this test method. All procedures specified herein are applicable, excepting requirements for wood species and specific gravity, and thicknesses of bondlines.

1.3 The values stated in inch-pound units are to be regarded as standard. The values given in parentheses are mathematical conversions to SI units that are provided for information only and are not considered standard.

1.4 *This standard does not purport to address all of the safety concerns, if any, associated with its use. It is the responsibility of the user of this standard to establish appropriate safety and health practices and determine the applicability of regulatory limitations prior to use.*

2. Referenced Documents

2.1 ASTM Standards:²

- D 143** Test Methods for Small Clear Specimens of Timber
- D 905** Test Method for Strength Properties of Adhesive Bonds in Shear by Compression Loading

¹ This test method is under the jurisdiction of ASTM Committee D14 on Adhesives and is the direct responsibility of Subcommittee D14.70 on Construction Adhesives.

Current edition approved April 1, 2005. Published April 2005. Originally approved in 1980. Last previous edition approved in 1999 as D 3931–93a (1999)^ε 1.

² For referenced ASTM standards, visit the ASTM website, www.astm.org, or contact ASTM Customer Service at service@astm.org. For *Annual Book of ASTM Standards* volume information, refer to the standard's Document Summary page on the ASTM website.

D 1151 Test Method for Effect of Moisture and Temperature on Adhesive Bonds

E 171 Specification for Standard Atmospheres for Conditioning and Testing Materials

3. Terminology

3.1 Definitions:

3.1.1 *gap-filling adhesive, n*—an adhesive capable of forming and maintaining a bond between surfaces that are not close-fitting.

3.1.1.1 *Discussion*—Close-fitting is relative to a given material and industry; for example, standards in construction differ from standards in electronics. Some adhesives will bond by bridging without completely filling the gap; others by filling the gap completely.

4. Significance and Use

4.1 Structural design based on strength-of-materials principles requires knowledge of the mechanical properties of the structural components, including adhesives. By nature of their use, the most important property of adhesive is shear strength.

4.2 Shear strength measured by this test method is suitable for use in adhesive development, manufacturing quality control, and in materials performance specifications, as well as structural design.

5. Apparatus

5.1 *Testing Machine*, having a capacity of about 15 000 lb (6818 kg) in compression or of sufficient capacity to test the adhesive in use. The machine shall be fitted with a shearing tool containing a self-aligning seat to ensure uniform lateral distribution of the load. The machine shall be capable of maintaining a uniform rate of loading such that the load may be applied with a continuous motion of the movable head to maximum load at a rate of 9.20 in. (5.0 mm)/min with a permissible variation of $\pm 25\%$. The shearing tool shown in Fig. 1 of Test Method **D 905** has been found satisfactory. Locate the testing machine in an atmosphere such that the

moisture content of the specimens, developed under the conditions prescribed in 7.3, is not noticeably altered during testing.

6. Test Specimen and Sample

6.1 Test specimens for adhesive bonds shall conform to the form and dimensions shown in Fig. 1. Prepare bonded assemblies as described in 7.1. Prepare test specimens for testing as described in 7.2.

6.2 Determine mean shear strengths of bonds at bondline thicknesses of 0.006 and 0.060 in. (0.15 and 1.52 mm). Tests for strengths of bonds at other thicknesses, in addition to those specified, shall be optional upon agreement between the manufacturer and the user.

6.3 Test a minimum of 28 specimens, representing seven different bonded assemblies, to determine mean shear strengths of bonds at each bondline thickness.

7. Procedure

7.1 Preparation of Bonded Assemblies:

7.1.1 Prepare bonded assemblies with hard maple blocks (*Acer saccharum* or *Acer nigrum*) conditioned as described in 7.3. The blocks shall have a minimum specific gravity of 0.65, based on oven-dry weight and oven-dry volume (Note 1).

NOTE 1—A method for selecting maple blocks of satisfactory specific gravity is described in the Appendix of Test Method D 905. For reference tests, the specific gravity of blocks may be determined in accordance with the Weight and Moisture Content Section under Nail Withdrawal of Test Methods D 143.

7.1.1.1 These blocks shall be straight-grained and free of defects, including knots, splits, birdseye, short grain, decay, and any unusual discoloration within the shearing area. The blocks shall be of suitable size so that four test specimens can be cut from one test joint, as shown in Fig. 2. Blocks approximately 3/4 by 2 1/2 by 14 in. (19 by 63 by 356 mm) have

been found to be satisfactory for this purpose. The moisture content shall be from 8 to 10 % (conditions prescribed in 7.3.1) based on oven-dry weight as determined on representative samples in accordance with the final measurement section under radial and tangential shrinkage and the weighing section under moisture determination in Test Methods D 143. Surface the blocks just prior to gluing, preferably with a hand-feed jointer. Make sure the surfaces remain unsanded and free from dirt.

7.1.2 Use spacer strips to control bondlines to specified thicknesses between blocks. Spacers shall be wood veneer or plastic, and measure approximately 1/2 by 3 1/2 in. (13 by 89 mm) long. Place spacers crosswise at the ends and center of the lower test joint block. Apply adhesive in sufficient quantity to ensure squeezeout at the ends of the joint when blocks are under pressure (Note 2).

NOTE 2—If the adhesive is to be applied as an extruded bead, the bead should be 3/8 to 1/2 in. (10 to 13 mm) in diameter to ensure squeezeout in bondline thicknesses near 0.060 in. (1.5 mm). Use a smaller diameter bead of adhesive for thinner bondlines.

7.1.2.1 Take care to avoid air entrapment in the bondline. Do not spread the adhesive closer than 1/2 in. (13 mm) to any spacer because adhesive may be entrapped between block and spacer, thereby increasing bondline thickness. Assemble the blocks immediately, unless specified otherwise by agreement between the manufacturer and user of the adhesive. Apply a 15-lb (7.0-kg) load uniformly over the entire bond area to ensure firm contact between spacers and blocks of the assembly. Maintain the pressure on test joints at the conditions prescribed in 7.1.

7.1.3 Curing time for bonded assemblies shall be as specified by the manufacturer of the adhesive, or else 30 days in the standard atmosphere (7.3.1).

7.2 Preparation of Test Specimens:

TABLE 1

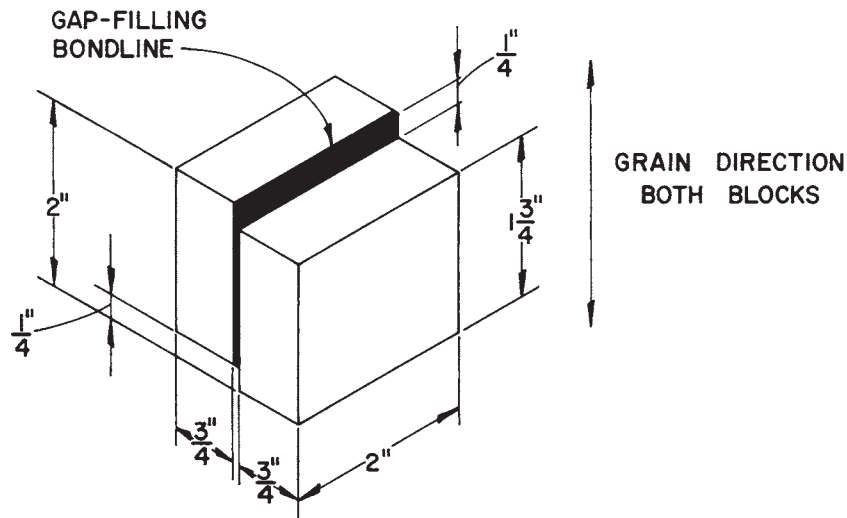

Metric Equivalents					
in.	0.064	1/4	3/4	1 1/4	2
mm	1.63	6.35	19.05	44.45	50.80

FIG. 1 Form and Dimensions of Test Specimen